

Ambient Light Sensor in 0805 Package

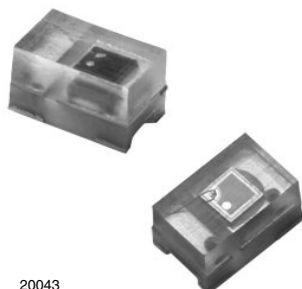

20043

DESCRIPTION

TEMT6200FX01 ambient light sensor is a silicon NPN epitaxial planar phototransistor in a miniature transparent 0805 package for surface mounting. It is sensitive to visible light much like the human eye and has peak sensitivity at 550 nm.

FEATURES

- Package type: surface mount
- Package form: 0805
- Dimensions (L x W x H in mm): 2 x 1.25 x 0.85
- AEC-Q101 qualified
- High photo sensitivity
- Adapted to human eye responsivity
- Supression filter for near infrared radiation
- Angle of half sensitivity: $\varphi = \pm 60^\circ$
- Floor life: 168 h, MSL 3, acc. J-STD-020
- Lead (Pb)-free reflow soldering
- Compliant to RoHS directive 2002/95/EC and in accordance to WEEE 2002/96/EC



RoHS
COMPLIANT



APPLICATIONS

- Automotive sensors
- Ambient light sensor for display backlight dimming in:
 - Mobile phones
 - Notebook computers
 - PDAs
 - Cameras
 - Dashboards

PRODUCT SUMMARY

COMPONENT	I_{PCE} (μA)	φ (deg)	$\lambda_{0.5}$ (nm)
TEMT6200FX01	7.5 to 39	± 60	450 to 610

Note

Test condition see table "Basic Characteristics"

ORDERING INFORMATION

ORDERING CODE	PACKAGING	REMARKS	PACKAGE FORM
TEMT6200FX01	Tape and reel	MOQ: 3000 pcs, 3000 pcs/reel. Label with I_{PCE} group on each reel. Specifications of group A/B/C see table "Type Dedicated Characteristics"	0805

Note

MOQ: minimum order quantity

ABSOLUTE MAXIMUM RATINGS

PARAMETER	TEST CONDITION	SYMBOL	VALUE	UNIT
Collector emitter voltage		V_{CEO}	6	V
Emitter collector voltage		V_{ECO}	1.5	V
Collector current		I_C	20	mA
Power dissipation		P_V	100	mW
Junction temperature		T_j	100	$^\circ C$
Operating temperature range		T_{amb}	- 40 to + 100	$^\circ C$
Storage temperature range		T_{stg}	- 40 to + 100	$^\circ C$
Soldering temperature	Acc. reflow profile fig. 9	T_{sd}	260	$^\circ C$
Thermal resistance junction/ambient	Soldered on PCB with pad dimensions: 4 mm x 4 mm	R_{thJA}	450	K/W

Note

$T_{amb} = 25^\circ C$, unless otherwise specified

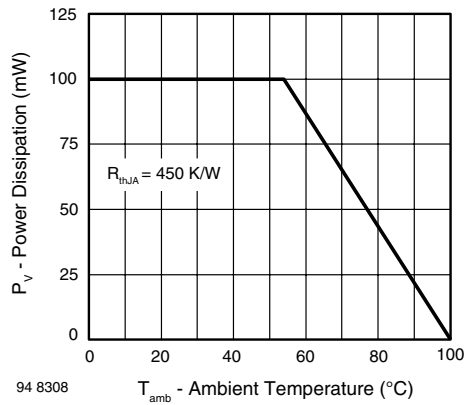

Fig. 1 - Power Dissipation Limit vs. Ambient Temperature

BASIC CHARACTERISTICS						
PARAMETER	TEST CONDITION	SYMBOL	MIN.	TYP.	MAX.	UNIT
Collector emitter breakdown voltage	$I_C = 0.1 \text{ mA}$	V_{CEO}	6			V
Collector dark current	$V_{CE} = 5 \text{ V}, E = 0 \text{ lx}$	I_{CEO}		3	50	nA
Collector emitter capacitance	$V_{CE} = 0 \text{ V}, f = 1 \text{ MHz}, E = 0 \text{ lx}$	C_{CEO}		16		pF
Photo current	$E_V = 20 \text{ lx}, \text{ CIE illuminant A}, V_{CE} = 5 \text{ V}$	I_{PCE}		4.6		μA
	$E_V = 100 \text{ lx}, \text{ CIE illuminant A}, V_{CE} = 5 \text{ V}$	I_{PCE}	7.5		39	μA
Temperature coefficient of I_{PCE}	CIE illuminant A	TK_{IPCE}		1.18		%/K
	LED, white	TK_{IPCE}		0.9		%/K
Angle of half sensitivity		ϕ		± 60		deg
Wavelength of peak sensitivity		λ_p		550		nm
Range of spectral bandwidth		$\lambda_{0.5}$		450 to 610		nm
Collector emitter saturation voltage	$E_V = 20 \text{ lx}, 0.45 \mu\text{A}$	V_{CEsat}		0.1		V

Note
 $T_{amb} = 25 \text{ }^\circ\text{C}$, unless otherwise specified

TYPE DEDICATED CHARACTERISTICS						
PARAMETER	TEST CONDITION	SELECTION TYPE	SYMBOL	MIN.	MAX.	UNIT
Photo current	$E_V = 100 \text{ lx}, \text{ CIE illuminant A}, V_{CE} = 5 \text{ V}$	TEMT6200FX01A	I_{PCE}	7.5	15	μA
		TEMT6200FX01B	I_{PCE}	12	24	μA
		TEMT6200FX01C	I_{PCE}	19.5	39	μA

Note
 $T_{amb} = 25 \text{ }^\circ\text{C}$, unless otherwise specified

BASIC CHARACTERISTICS

$T_{amb} = 25\text{ }^{\circ}\text{C}$, unless otherwise specified

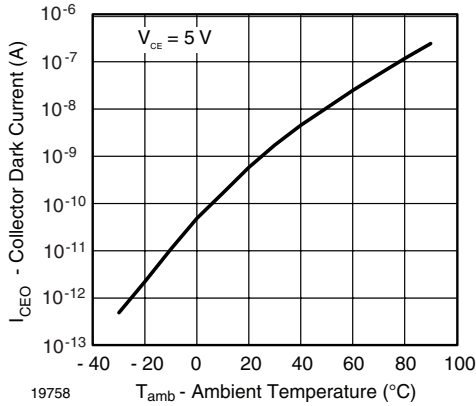

Fig. 2 - Collector Dark Current vs. Ambient Temperature

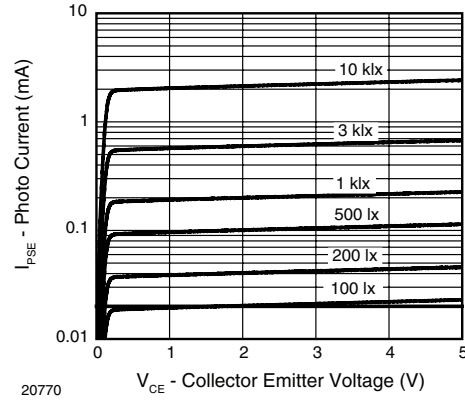

Fig. 5 - Photo Current vs. Collector Emitter Voltage

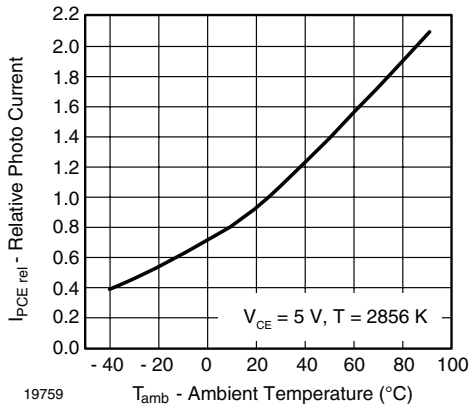

Fig. 3 - Relative Photo Current vs. Ambient Temperature

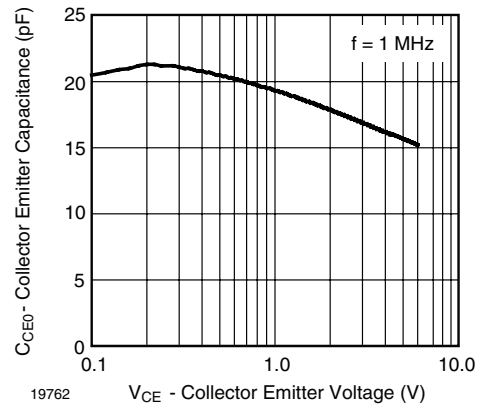

Fig. 6 - Collector Emitter Capacitance vs. Collector Emitter Voltage

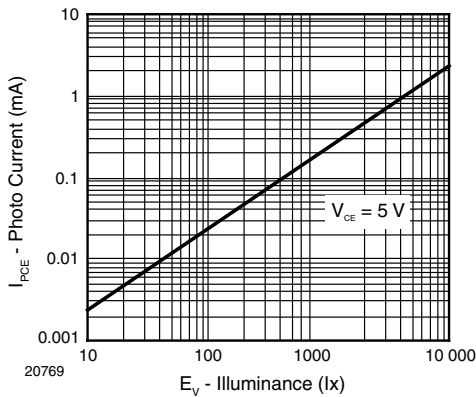

Fig. 4 - Photo Current vs. Illuminance

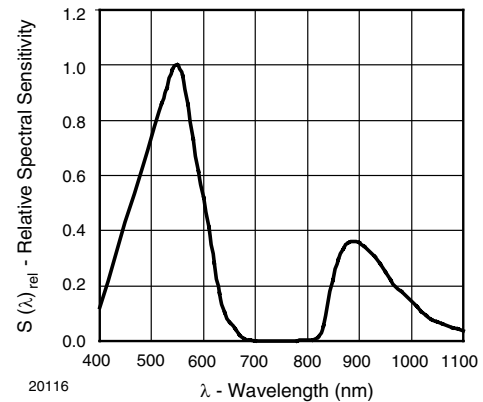

Fig. 7 - Relative Spectral Sensitivity vs. Wavelength

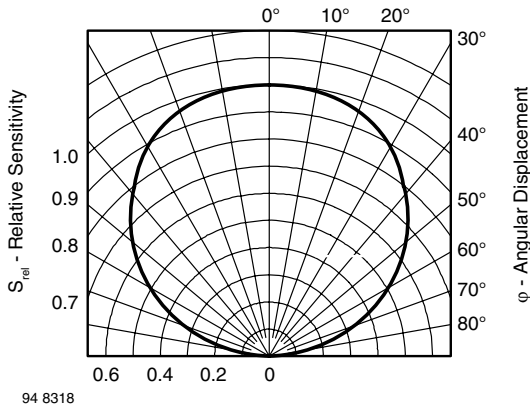

Fig. 8 - Relative Radiant Sensitivity vs. Angular Displacement

REFLOW SOLDER PROFILE

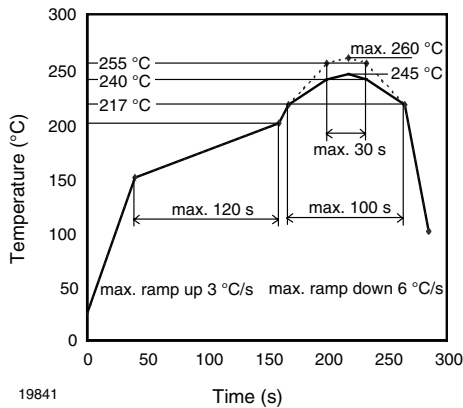

Fig. 9 - Lead (Pb)-free Reflow Solder Profile acc. J-STD-020D

DRYPACK

Devices are packed in moisture barrier bags (MBB) to prevent the products from moisture absorption during transportation and storage. Each bag contains a desiccant.

FLOOR LIFE

Time between soldering and removing from MBB must not exceed the time indicated in J-STD-020:
 Moisture sensitivity: level 3
 Floor life: 168 h
 Conditions: $T_{amb} < 30\text{ }^{\circ}\text{C}$, $RH < 60\%$

DRYING

In case of moisture absorption devices should be baked before soldering. Conditions see J-STD-020 or label. Devices taped on reel dry using recommended conditions 192 h at $40\text{ }^{\circ}\text{C}$ (+ $5\text{ }^{\circ}\text{C}$), $RH < 5\%$.

TEMT6200FX01

Vishay Semiconductors

Ambient Light Sensor in 0805
Package



PACKAGE DIMENSIONS in millimeters

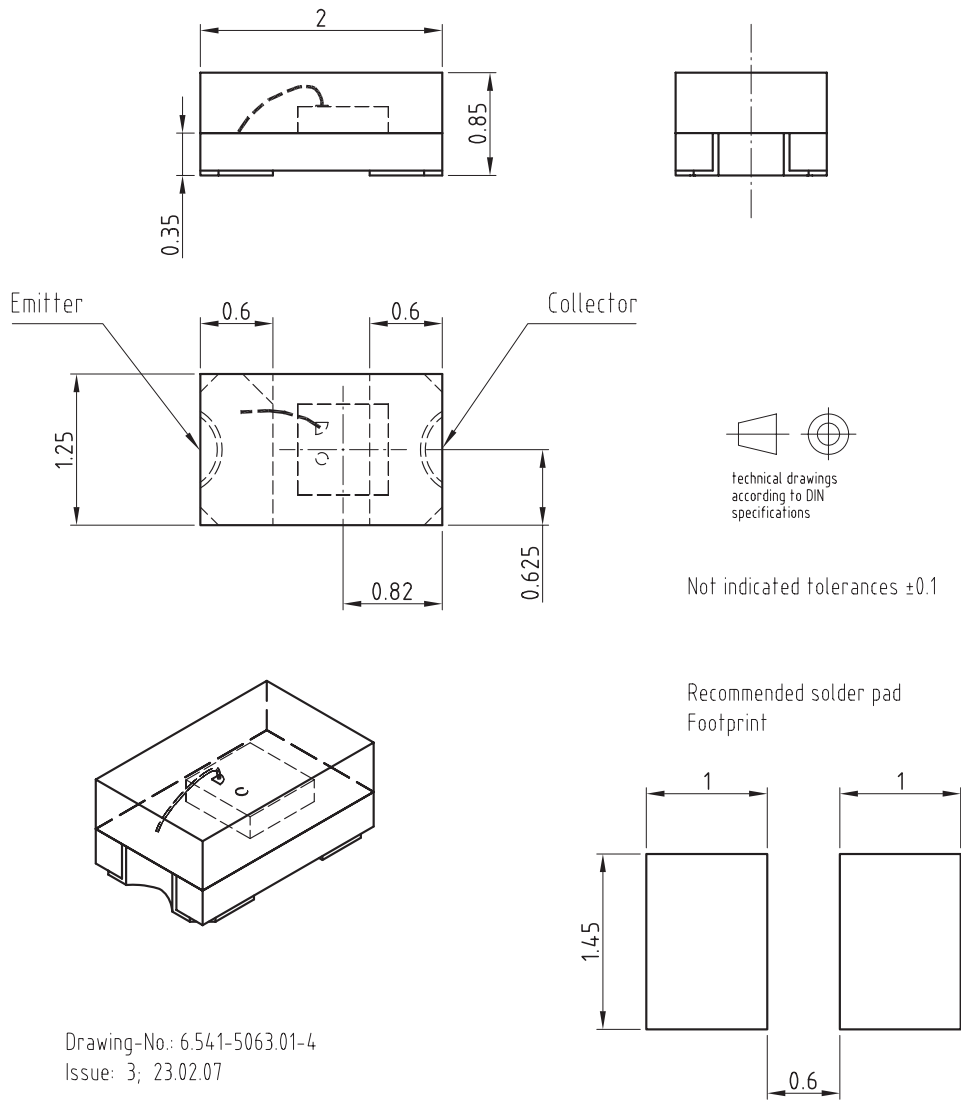

BLISTER TAPE DIMENSIONS in millimeters

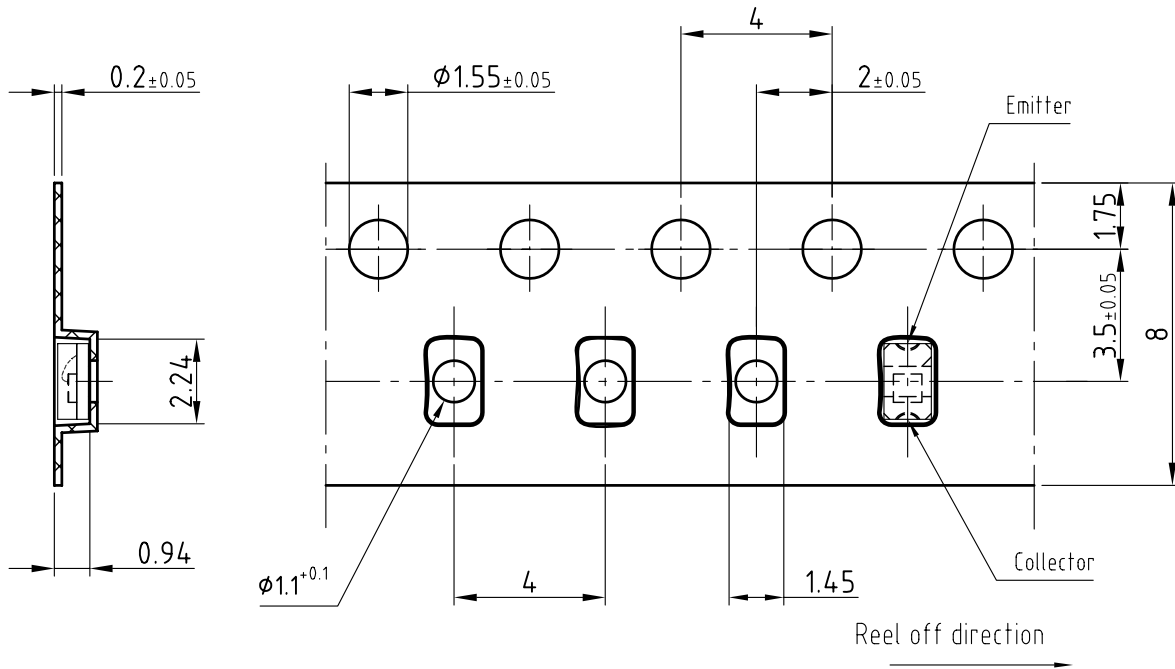

Drawing-No.: 9.700-5310.01-4
 Issue: 2; 14.08.07
 20690

Not indicated tolerances ±0.1

Quantity per reel: 3000 pcs

technical drawings according to DIN specifications

TEMT6200FX01

Vishay Semiconductors

Ambient Light Sensor in 0805
Package



REEL DIMENSIONS in millimeters

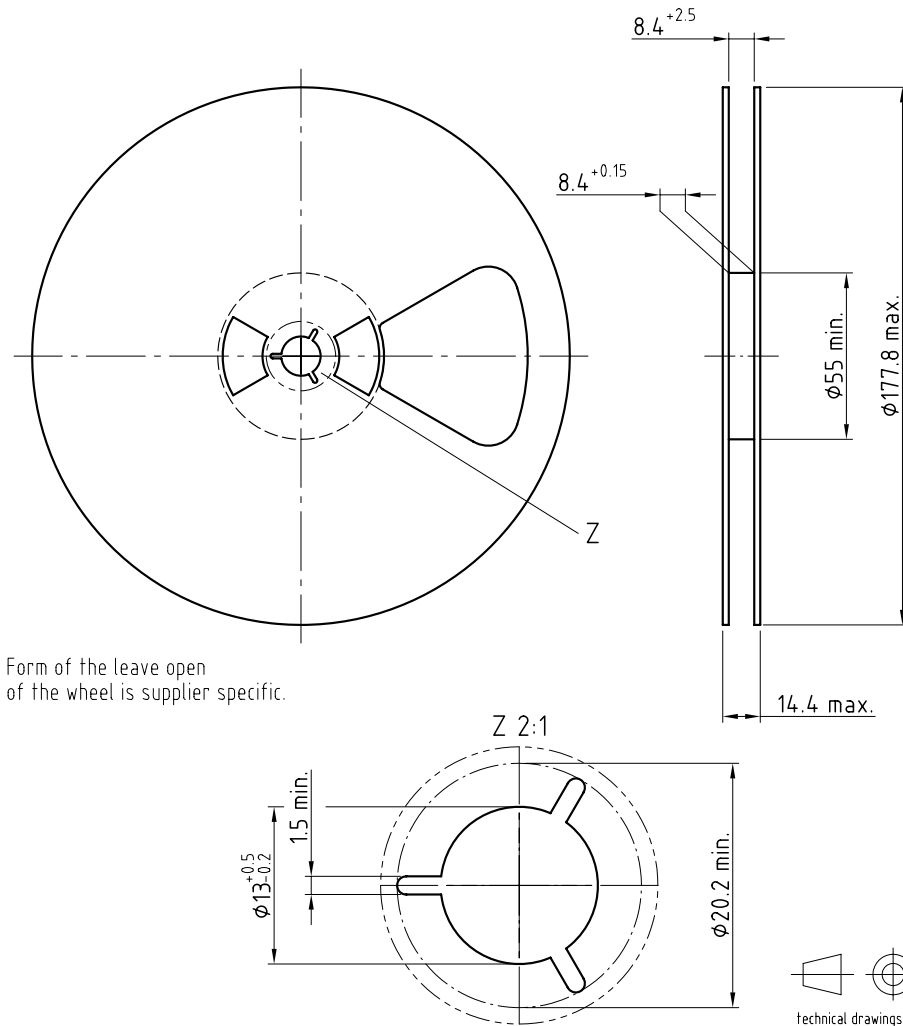

Drawing-No.: 9.800-5096.01-4

Issue: 1; 05.05.08

20875



Disclaimer

All product specifications and data are subject to change without notice.

Vishay Intertechnology, Inc., its affiliates, agents, and employees, and all persons acting on its or their behalf (collectively, "Vishay"), disclaim any and all liability for any errors, inaccuracies or incompleteness contained herein or in any other disclosure relating to any product.

Vishay disclaims any and all liability arising out of the use or application of any product described herein or of any information provided herein to the maximum extent permitted by law. The product specifications do not expand or otherwise modify Vishay's terms and conditions of purchase, including but not limited to the warranty expressed therein, which apply to these products.

No license, express or implied, by estoppel or otherwise, to any intellectual property rights is granted by this document or by any conduct of Vishay.

The products shown herein are not designed for use in medical, life-saving, or life-sustaining applications unless otherwise expressly indicated. Customers using or selling Vishay products not expressly indicated for use in such applications do so entirely at their own risk and agree to fully indemnify Vishay for any damages arising or resulting from such use or sale. Please contact authorized Vishay personnel to obtain written terms and conditions regarding products designed for such applications.

Product names and markings noted herein may be trademarks of their respective owners.